

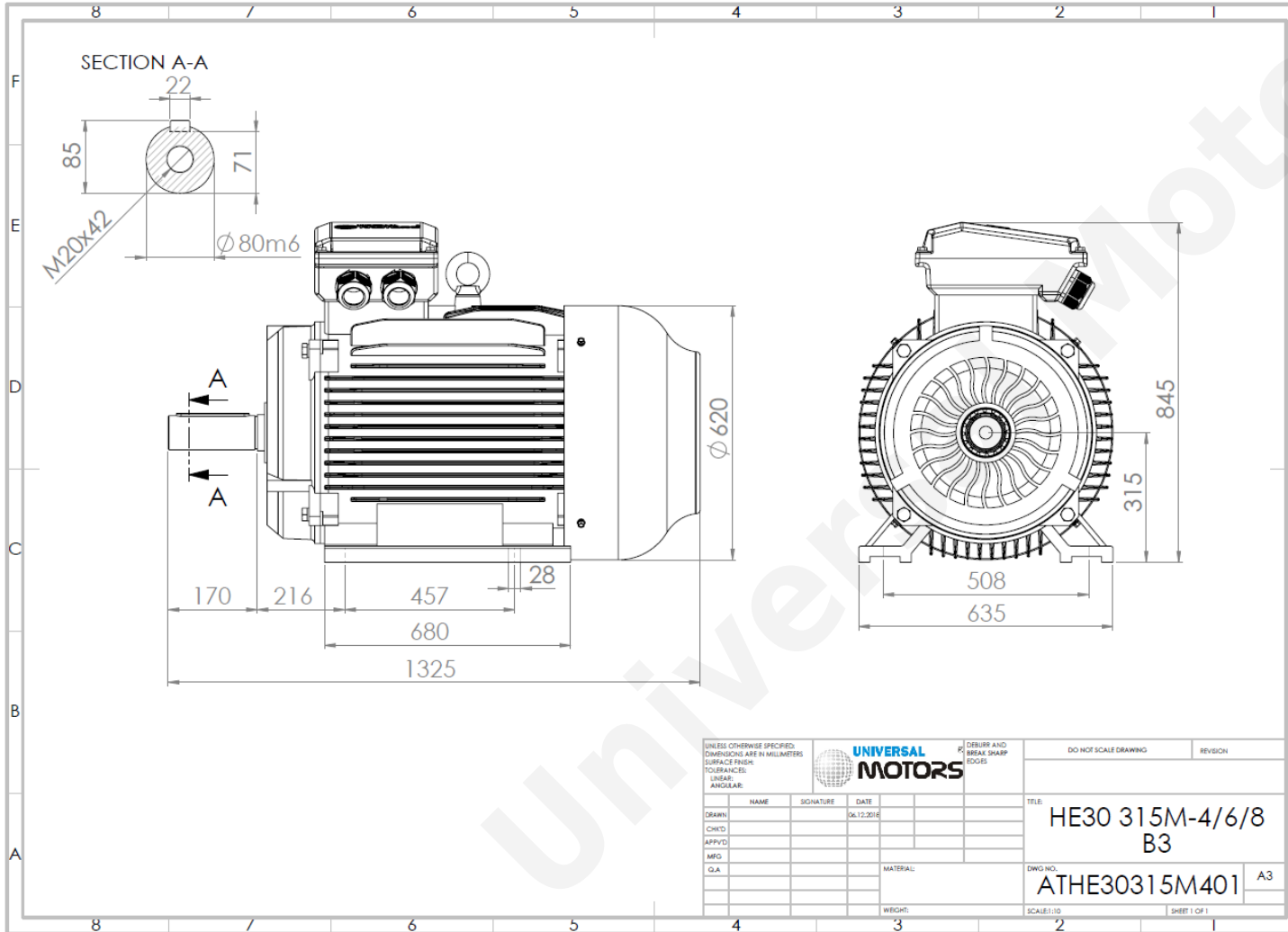

# TECHNICAL DATA

Three Phase Electric Motors - Cast Iron Frame  
 HE30 315 M-6 IE2  
 90 kW / 125 Cv  
 990 RPM



Motor type:	HE30 315 M-6 IE2
Output:	90 kW / 125 Cv
Speed (min <sup>-1</sup> ):	990 RPM
Frequency:	50 Hz
Voltage:	400 V
Current:	161 A
Power factor (Cos $\phi$ ):	0.86
Poles:	6
Insulation class:	F
Temperature rise Class:	B
Efficiency 50%:	93.7 %
Efficiency 75%:	94.3 %
Efficiency 100%:	94.0 %
Torque:	868 N.m
Tstarting/Tnominal:	2.0
Istarting/Inominal:	6.7
Tmaximum/Tnominal:	2.0
Noise:	72 Db(A)
Weight:	850 Kg
Bearing DE:	NU 319
Bearing NDE:	6319 C3

Regime - S1

Altitude - 1000m

Environment Temperature - 40°C

## CONTACTS:

UNIVERSAL MOTORS Tel: +351 252 299 080  
 Rua de São Brás, 745 Fax: +351 252 299 089  
 4480-782 VILA DO CONDE Mail: [geral@universalmotors.pt](mailto:geral@universalmotors.pt)

\* References applied only in the UK